

SPRINGS  
**FABRICATION**

**GET TO KNOW**

**SPRINGS FABRICATION, LLC**

A DIVISION OF

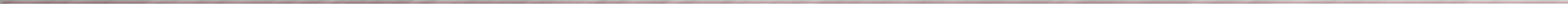
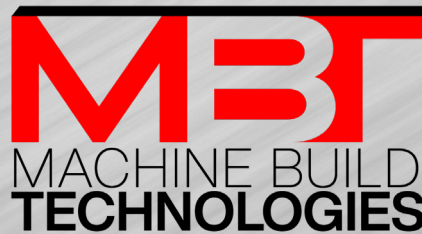



# CONTENTS

1. ABOUT US

---

2. CAPABILITIES & CORE COMPETENCIES

---

3. QUALITY MANAGEMENT SYSTEMS

---

4. CYBERSECURITY

---

5. PRODUCTS / PROJECTS

---



# ABOUT US



# NATIONAL LEADER IN FABRICATION

TC-300 Flotation Cells, Bagdad AZ / Outotec



# ABOUT US

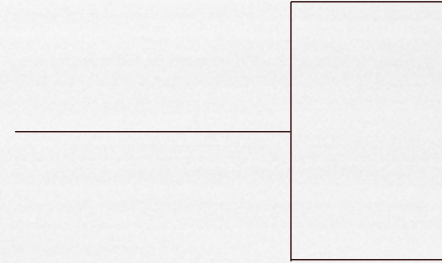

Once a two-man job shop, Springs Fabrication is **now part of the Machine Build Technologies family** along with Springs ATG.

# ABOUT US

## FACILITIES



**COLORADO SPRINGS** | 105,000 SQ. FT.



**DENVER (SPRINGS ATG)** | 85,000 sq. ft.

# ABOUT US

## FACILITIES

**Approximately 200,000 square feet** of industry leading high bay manufacturing facilities.

Approximately **170 employees**.

With the **capabilities to manufacture** products from simple weldments and custom pressure vessels to fully engineered skidded systems and large CNC machine capacity for industrial sized weldments.



Since 1986, Springs Fabrication has been serving the needs of companies nationwide with quality machining and fabrication services.

Our focus and commitment towards delivering complex, high-end engineered metal products across a wide range of industries has been the cornerstone of our continued success.

Through our responsiveness, quality, performance and value-added services, Springs Fabrication is able to enjoy mutually successful relationships with its customers.





# FACILITIES



# COLORADO SPRINGS

## FABRICATION FACILITY



- Modern 105,000 square foot facility on 11 acres
- Large 100 ft. x 450 ft. fabrication bay
- (2) 100 ft. span, 40-ton double trolley bridge crane x 32 ft. under hook height servicing large fabrication bay
- Assembly bay 50 ft. x 100 ft. with (2) 15 ton cranes x 55 ft. under hook height
- Precision floor imbeds in multiple locations allow us to accurately fixture and align large fabrications.
- Indoor reclaim blast booth, 20 ft. x 24 ft. x 70 ft. with inlaid track
- Climate controlled paint booth, 16 ft. x 18 ft. x 75 ft. with inlaid track



**CAPABILITIES**

**CORE COMPETENCIES**

# CAPABILITIES & CORE COMPETENCIES

- Engineering and Design Services
- Project Management
- Commercial and Contract Manufacturing
- Material Processing
- Code Welding Program
- Large Machining Capabilities – Lathes / Mills
- Finishing and Assembly
- Inspection and Testing



Ethanol Skid – Coors / Merrick & Co.



# ENGINEERING + DESIGN

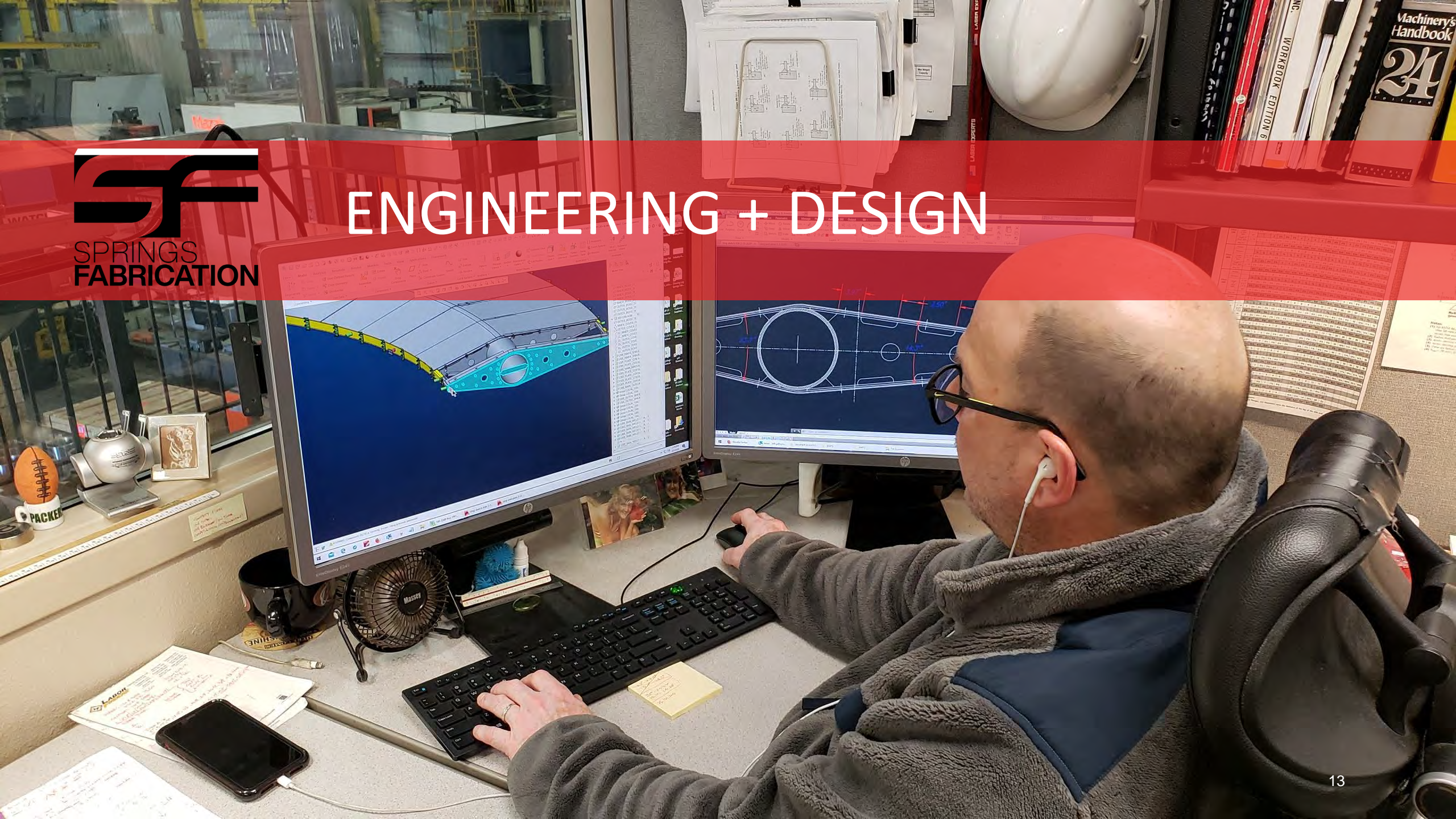

# ENGINEERING + DESIGN

Springs Fabrication has a diverse range of experience from the design of simple parts to engineering complex equipment and systems.

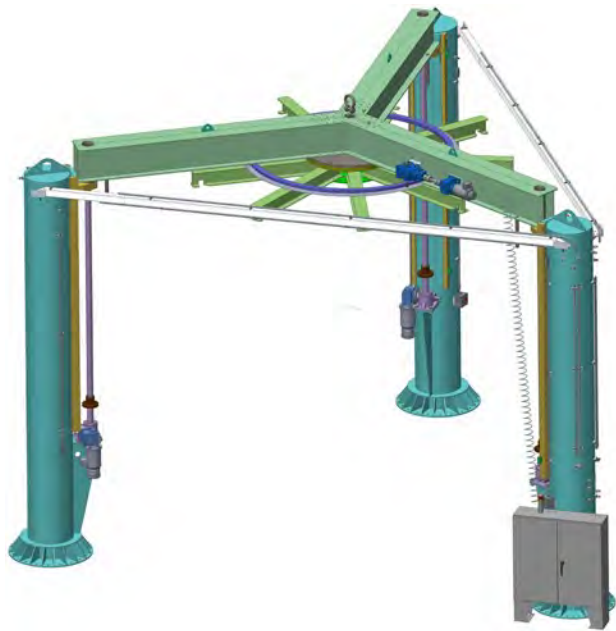

**DESIGN + ENGINEERING: Coil Stacking Tool – ITER / General Atomics**

# ENGINEERING + DESIGN

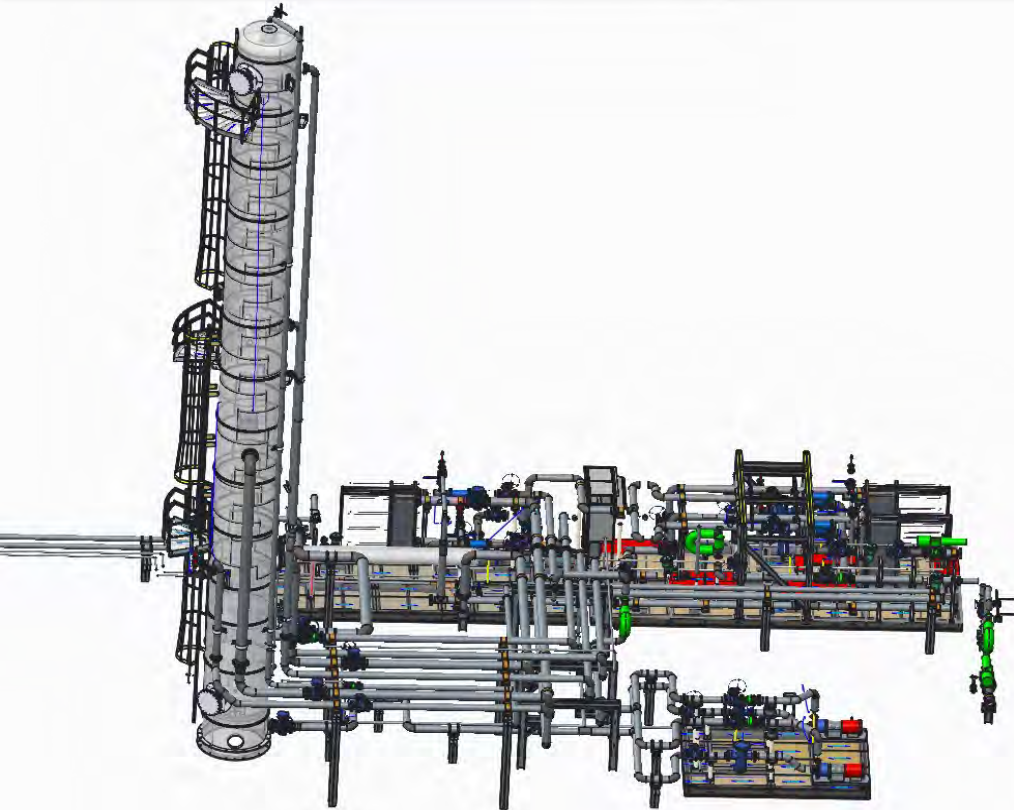

## KEYS TO PROVIDING TIMELY, QUALITY PRODUCTS:

- design for manufacturing capabilities
- engineer and perform analysis
- manufacture, assemble and test

*In the early phases of each project, our experienced design team conducts a comprehensive design review, laying the groundwork for a seamless transition from engineering to manufacturing.*

# DESIGN & ENGINEERING

## OUR DESIGN PROCESS SHORTENS LEAD TIME + IMPROVES ACCURACY

- **CREO (Pro/ENGINEER) and SolidWorks 3D Modeling software to construct scaled, 3D models.**
  - Designs optimized to reduce cost and shorten lead time
  - Drawings generated directly from the 3D Modeling software
- **AutoCAD is used to create 2D drawings:**
  - schematics
  - diagrams
  - P&IDs
- **We export part geometry, metadata, out of the design software directly to our post processing software and machining centers.**

Beam Shutter MACS – NIST / Merrick & Co.

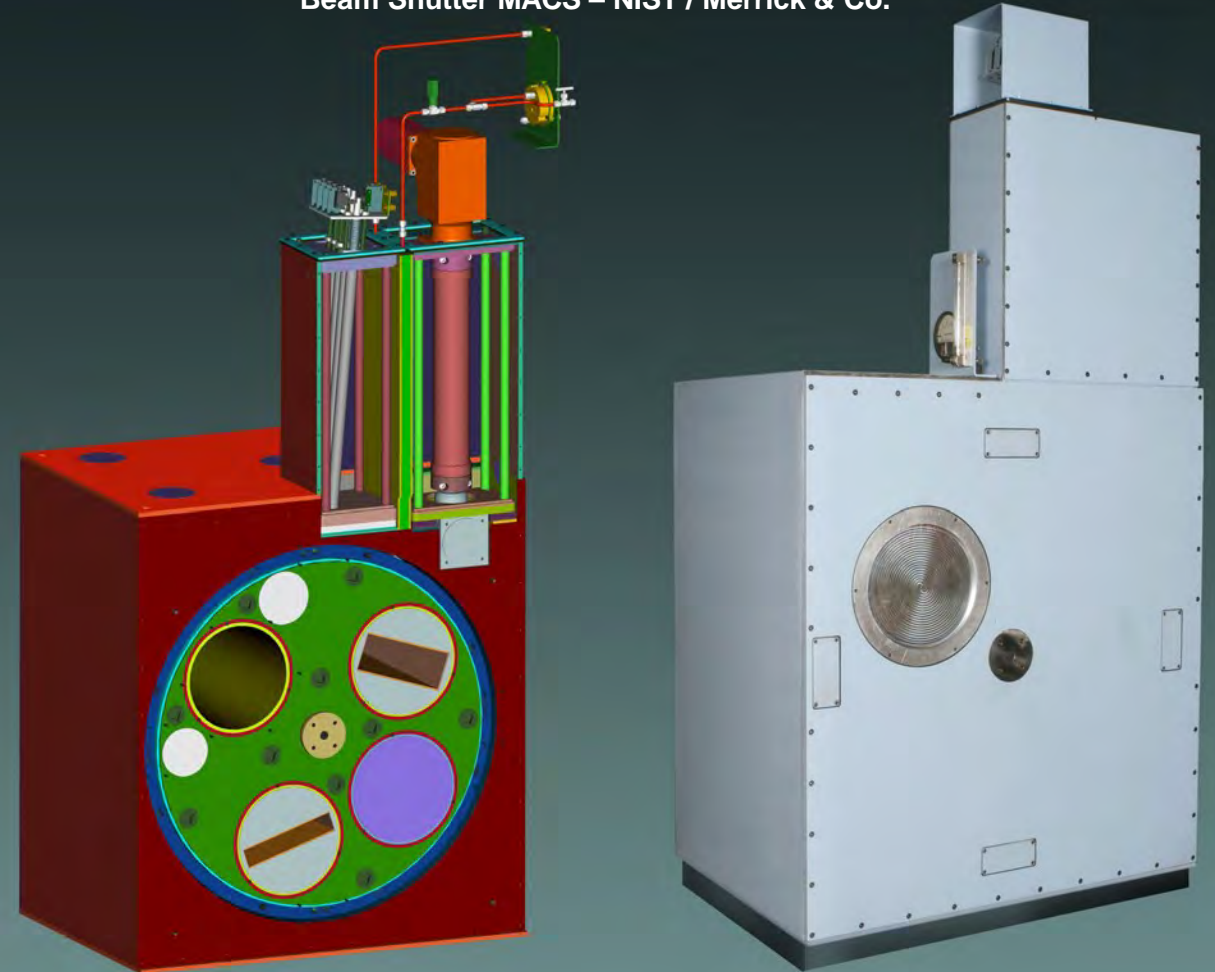





# PROJECT MANANGMENT

Bryan McCullar



# PROJECT MANAGEMENT

## UPON AWARD AND ACCEPTANCE

the project is assigned to a project management team responsible for all coordination and execution.

## PROJECT MANAGEMENT TEAM INCLUDES

- Project manager
- Project/Manufacturing engineer
- Quality, welding engineering, and procurement are shared resources and support the project as required

## THE PROJECT MANAGER IS

- responsible for the project and providing updates, correspondence, project submittals, and scheduling updates
- responsible for defining the Project Execution Plan
- the primary point of contact with the customer

Water Jet Peening Bridge System - Wolf Creek Nuclear Operating Corporation and Mitsubishi Heavy Industries subsidiary, Mitsubishi Nuclear Energy Systems (MNES) / AZZ

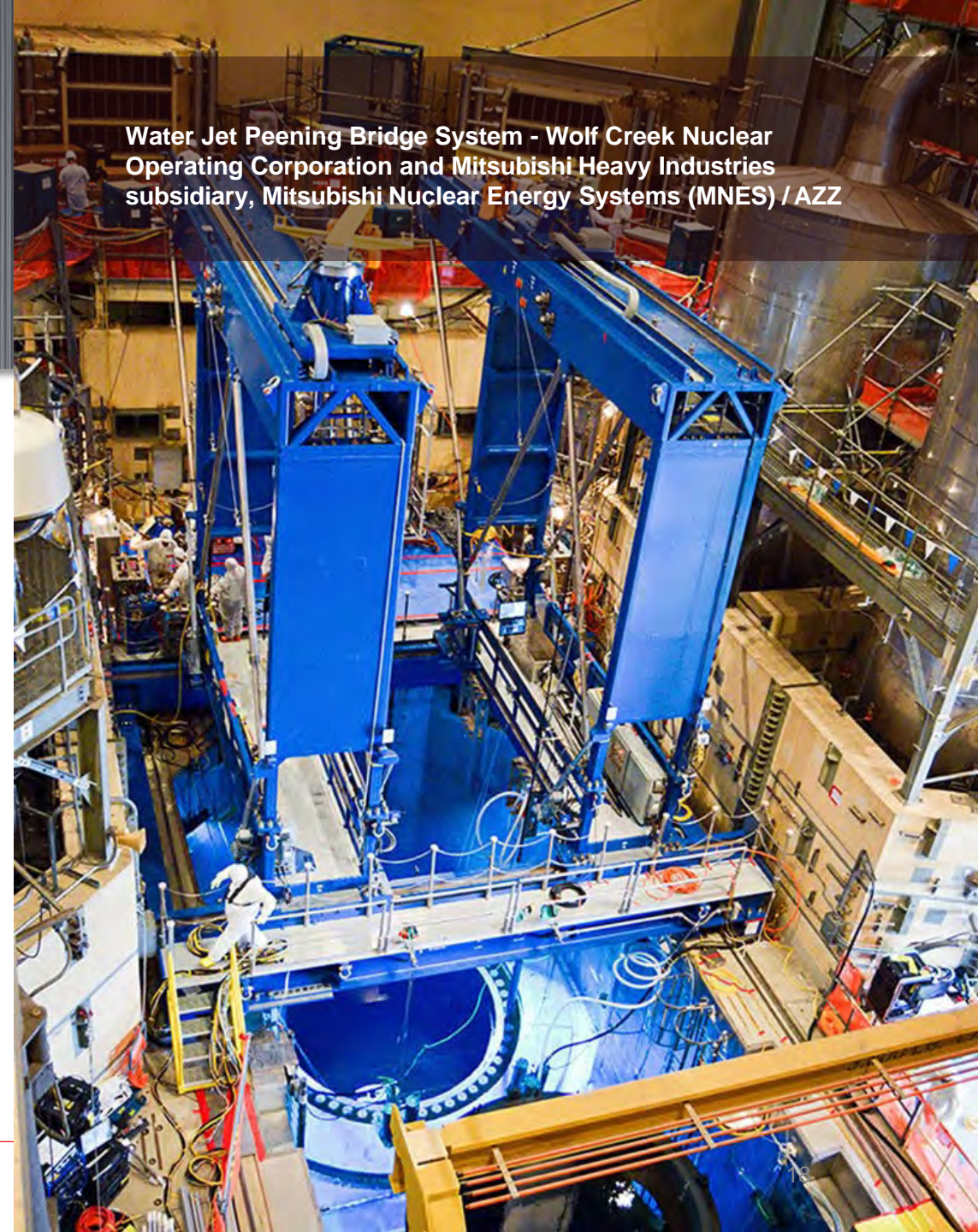



# COMMERCIAL / CONTRACT MANUFACTURING



# COMMERCIAL / CONTRACT MANUFACTURING

Recognized as one of the leading and most capable metal fabricators in the Rocky Mountain region, Springs Fabrication offers over 30 years of design and manufacturing excellence.

As the supplier-of-choice for several leading industrial companies, Springs Fabrication has a track record of forming strong, productive partnerships with our customers. Our experienced team ensure that the products meet all of your specifications.

## INDUSTRY EXPERIENCE

New & Existing Energy | Mining & Remediation | Aerospace  
Infrastructure | General Industry | Railroad  
Top 10 Engineering Firms | National Laboratories | Nuclear  
Department of Defense (DOD) | Department of Energy (DOE)



Compressor Skid / UE Compression



# MATERIAL PROCESSING



# MATERIAL PROCESSING

## EQUIPMENT HIGHLIGHTS

- Mazak tube laser w/ tapping: Pipe, Tube, Angle, Beam, etc. up to 8.63" diameter
  - Mazak flat laser: 78" x 157" travel shuttle table
  - Kinetic 4000: 8' x 20' table, 260A HD plasma, Oxy Fuel, Machining Head
  - Kinetic 2500: 10' x 24' table, twin 260AHD plasma
  - Saws: up to 24" x 24"
  - Rolling: Plate/Sheet - Up to 1-5/8" thick x 12' wide A36, up to 3" thick depending on width
  - Forming: Press Brake - Up to 200-ton x 12' wide
-

# A CLOSER LOOK

## 6-AXIS TUBE LASER CAPABILITY

Precision without machining



Round Tube/Pipe



Square &  
Rectangular Tube



Angle



Beam



Weld Prep



Slot and Tab  
(Self-fixturing)



And more.



# CODE WELDING PROGRAM





# WELDING PROGRAM

Our welding program is a mature and robust program administered in accordance with the requirements set forth in Section IX of *the ASME Boiler and Pressure Vessel Code* and the *AWS construction codes*.

# WELDING PROGRAM

A welder wearing a white hard hat, safety glasses, and a high-visibility vest is working on a large industrial vessel. The welder is positioned on a yellow metal structure, possibly a scaffolding or part of the vessel's support. The background shows a large industrial building with a corrugated metal roof and various pipes and cables. The scene is brightly lit, suggesting an indoor industrial environment.

- Administered by in-house **welding engineers** with weld inspections performed by our AWS CWIs (Certified Welding Inspectors).
- Qualified for use in welding of ASME Section VIII, Division 1 pressure vessels and ASME B31 series piping.



# WELDING PROGRAM

***WELDING PROCESSES***  
**GMAW, FCAW, GTAW and SAW**

***MATERIALS***  
Carbon steel,  
300 series stainless steel,  
aluminum and nickel alloys.

Springs Fabrication has dedicated stainless steel fabrication bays for the mitigation of cross-contamination





# MACHINING - LATHES



# EQUIPMENT HIGHLIGHTS

## LATHES

Samsung CNC with live tool & steady rest, 30" x 130"

Haas SL30 with servo 800 bar feeder, 17" x 34"

Mazak Integrex 200s, 5-Axis

HNK VTL with live tool, 78" Table with 98" swing



Adapter, 5MW Dynamometer Facility /  
NREL National Wind Technology Center



# MACHINING - MILLS



Coil Support Frame, ITER / General Atomics



# EQUIPMENT HIGHLIGHTS

## MILLS

**G&L Horizontal:** 360" x 96" x 48", 120" sq. rotary infeed table

**Femco Horizontal:** 78" x 70" x 66", 4<sup>th</sup> Axis available

**Mazak Horizontal:** 52" x 48" x 48", 4<sup>th</sup> Axis, dual pallet

**Feeler Bridge:** 205" x 94" x 47", right angle head

**Chevalier Bridge:** 162" x 101" x 39", right angle head

**Haas VF6:** 64" x 32" x 30", 4<sup>th</sup> Axis available

**Haas VF4SS:** 50" x 20" x 25", 4<sup>th</sup> Axis available





# INSPECTION AND TESTING

# INSPECTION + TESTING HIGHLIGHTS

## MEASURING AND TEST EQUIPMENT

M&TE is calibrated, documented and traceable to NIST Standards.

In addition to a large variety of standard metrology available for use, we have the following instruments:

*FARO 3D Laser Tracker – 250 ft Cube*

*FARO Arm, Platinum – 6 ft Cube*

*Bruker XRF PMI (Positive Material Identification) Analyzer*

*Vacuum Pump System and Helium Tester*

*Olympus UT Thickness instrument*

*Digital Psychrometer (environmental conditions)*



# INSPECTION + TESTING HIGHLIGHTS

## CERTIFICATIONS



In-House capabilities:

Level II SNT-TC-1A Examiners

VT – Visual

MT – Magnetic Particle

PT – Liquid Penetrant

BLT – Bubble Leak Testing

AWS QC1 Certified Welding Inspectors (CWI)



# FINISHING

**DANGER**  
NO SMOKING  
NO OPEN FLAMES  
NO SPARKS

**DANGER**  
NO SMOKING  
NO OPEN FLAMES  
NO SPARKS

Paint Booth: Viking climate controlled 18ft x 20ft x 75ft

# EQUIPMENT HIGHLIGHTS

## FINISHING

### ***BLAST BUILDING***

24ft x 20ft x 60ft with recovery floor

Available spray to waste system for virgin and specialty media

### ***PAINT BOOTH***

Viking climate controlled 18ft x 20ft x 75ft

In-floor rails for transferring product from blast building to and through paint booth





# ASSEMBLY

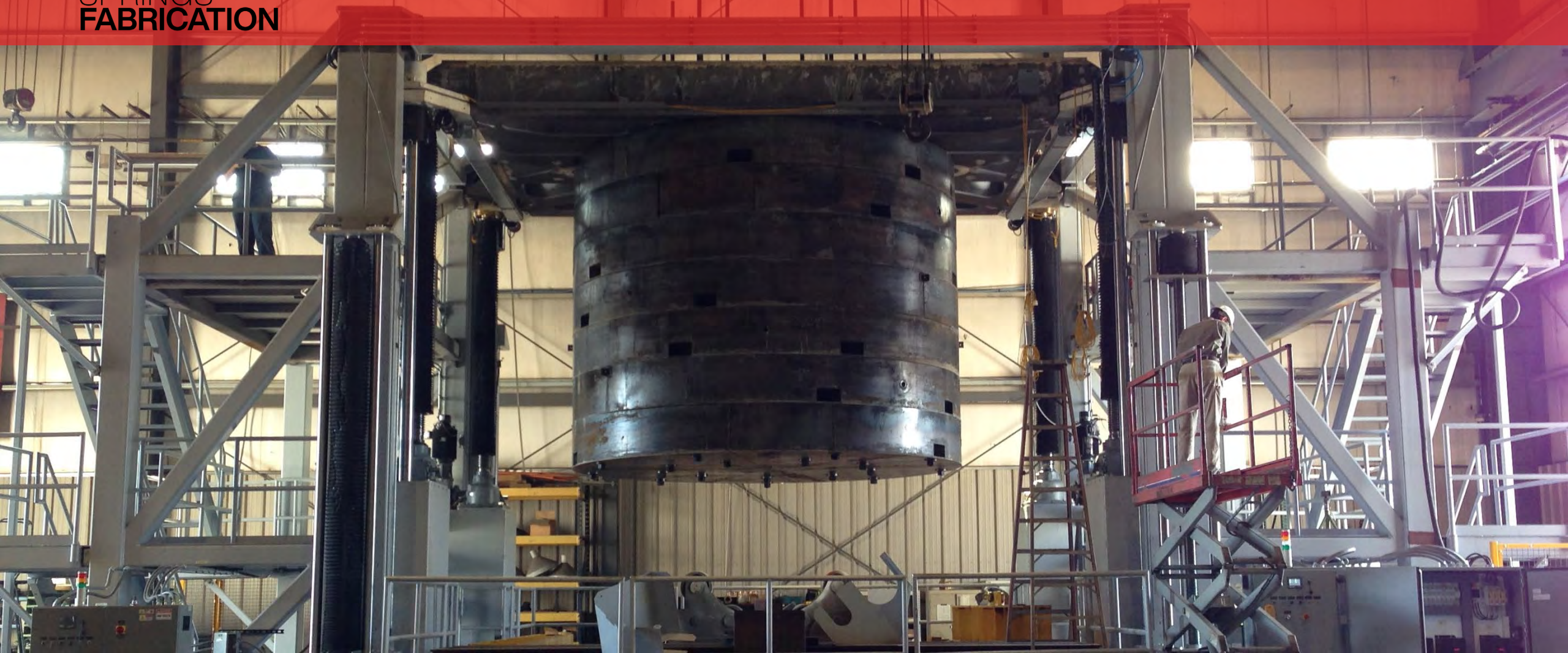



# EQUIPMENT HIGHLIGHTS

## ASSEMBLY

### ***MECHANICAL***

50ft x 100ft x 55ft under hook height

Assembly bay serviced by (2) 15 MT cranes and (1) 40T crane

### ***ELECTRICAL***

Termination, Conduit Runs, Ring-Out, Panel Install

Larger projects and/or licensed electricians subcontracted



**QUALITY  
MANAGEMENT  
SYSTEMS**



# QUALITY MANAGEMENT SYSTEMS

***Springs Fabrication operates three Quality Assurance Programs:***

## **QT-1 ISO 9001 Certified QMS**

Current edition certified through Orion Registrar, Inc.

## **QT-2 ASME NQA-1:2008 Compliant QMS**

Meets or exceeds the requirements of ASME NQA-1, 2008; Title 10, U.S. Code of Federal Regulations 830.122; DOE Order 414.1C; and Title 10, U.S. Code of Federal Regulations Part 50, Appendix B.

## **QT-3 ASME Section VIII, Division 1 Certified QMS**

ASME Certificate of Authorization "U" / NBIC Certificate of Authorizations "NB" & "R"



**CYBERSECURITY**

# CYBERSECURITY

## COMPLIANCE

### **In support of Cybersecurity compliance requirements for the handling of Controlled Unclassified Information (CUI) and Covered Defense Information (CDI):**

- We hold a medium level of assurance (MLOA) hardware digital certificate.
- Our information system is compliant with the requirements of FAR 52.204-21 “Basic Safeguarding of Covered Contractor Information Systems”.
- Our information system is compliant with the requirements of DFARS 252.204-7012 “Safeguarding Covered Defense Information and Cyber Incident Reporting”.
- We have implemented all 110 controls of National Institute of Standards and Technology (NIST) Special Publication (SP) 800-171 on our relevant information system.
- We have implemented Level 1, 2 and 3 controls of Cybersecurity Maturity Model Certification (CMMC).
- We have conducted a basic self-assessment of the 110 NIST 800-171 controls and submitted resulting scores to the Department of Defense (DoD) Website “Supplier Performance Rating System (SPRS)” (Ref DFARS 252.204-7019 and DFARS 252.204-7020 for additional information.)



# PRODUCTS

Water Jet Peening Bridge System - Wolf Creek Nuclear  
Operating Corporation and Mitsubishi Heavy Industries  
subsidiary, Mitsubishi Nuclear Energy Systems (MNES) / AZZ



# INDUSTRIAL PRODUCTS



# INDUSTRIAL PRODUCTS

## KEY INDUSTRIES

- New and Existing Energy
- Mining and Remediation
- Aerospace (Non-Flight)
- Infrastructure
- General Industry
- Railroad
- Top 10 Engineering Firms
- National Laboratories
- Department of Defense (DOD)
- Department of Energy (DOE)
- Nuclear

# INDUSTRIAL PRODUCTS

## KEY PRODUCTS

- Custom, High Specification Fabrication
- Skidded / Packaged Systems
- ASME Pressure Vessels / Heat Exchangers
- Atmospheric Tanks
- Pipe Spools / Piping Systems
- Industrial Rotary Equipment
- Vacuum Chambers
- Large Machined Weldments
- Ground Support Equipment (GSE) / Fixturing
- Bulkheads / Gates / Trashracks



# ORIGINAL EQUIPMENT MANUFACTURER (OEM)



Temporary Sound Mitigation Walls / Urban Solutions Group



# OEM

# KEY INDUSTRIES

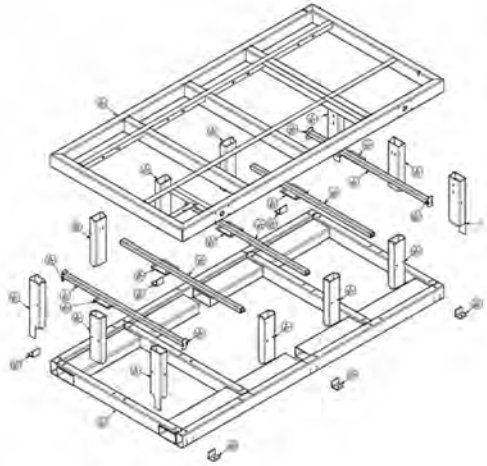

Machine Frame Kit / Oliver Manufacturing

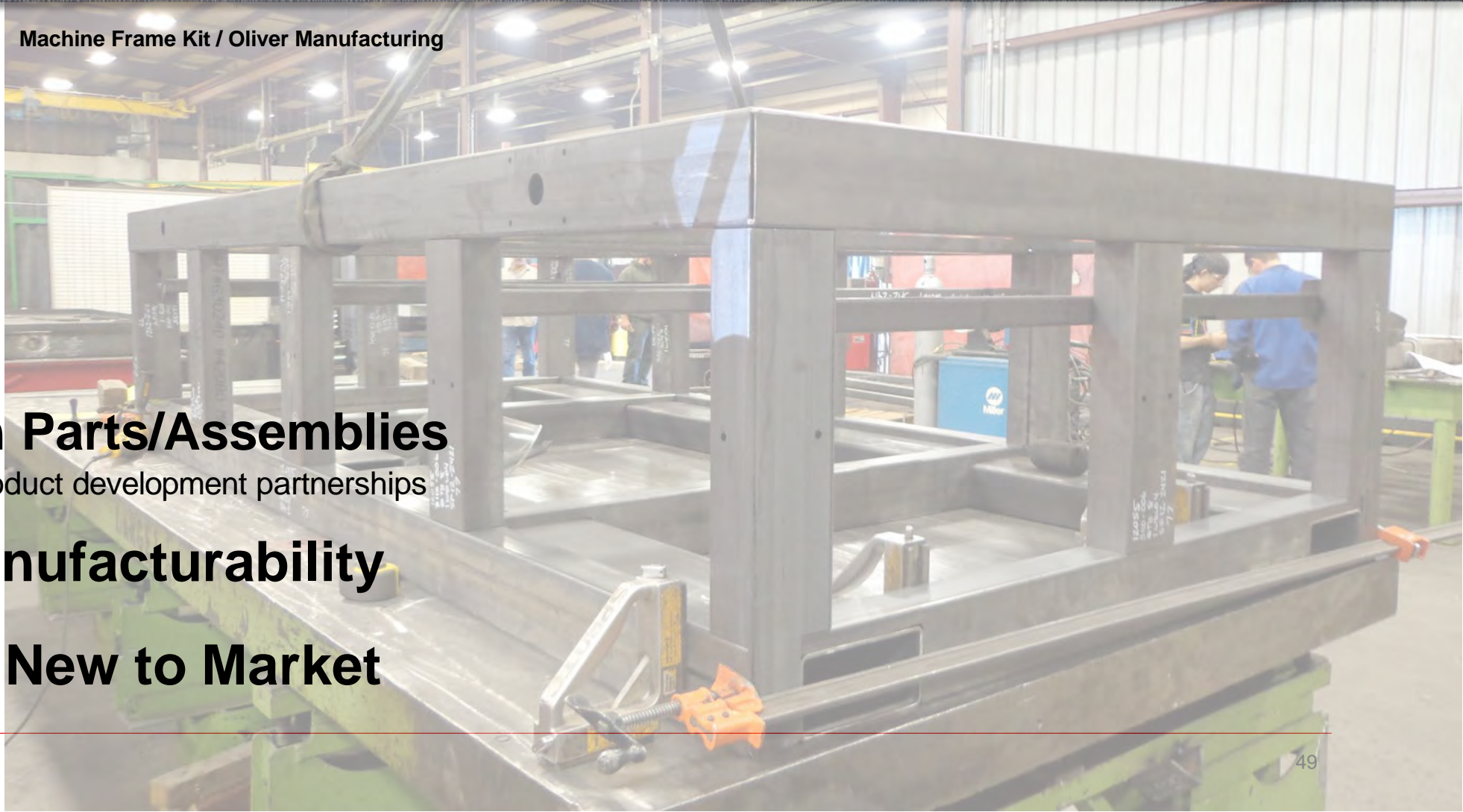

**Small-Med Run Parts/Assemblies**

Focused on early-stage product development partnerships

**Design for Manufacturability**

**Value-added / New to Market**



# ARTS + ENTERTAINMENT

Epicenter Sculpture – Switchbacks Football Club / Weidner Apartment Homes  
Weidner Field – Downtown Colorado Springs, CO





# ARTS + ENTERTAINMENT

## KEY INDUSTRIES

### Metal Art Sculptures

Providing manufacturability and engineering development

### Custom Venue Features

Focused on early-stage product development partnerships



# PROJECTS

SEE PROJECT SHEET FOR ADDITIONAL INFORMATION

# BIO REMEDIATION PLANT

Functional Acceptance Test (FAT) at Springs Fabrication Facility



Pueblo Chemical Agent-Destruction Pilot Plant (PCAAP)  
U.S Army Pueblo Chemical Depot (PCD), Pueblo, CO  
Bioreactor System/ Golder Associates

# STABILIZATION TOWER

Loaded for Shipment



Stabilizer Tower 6ft x 82ft / Anadarko Petroleum Corp.

# Ground Support Equipment (GSE)



Transport Container – Lockheed Martin

# ETHANOL PLANT

Waste Beer Ethanol Plant – Coors,  
Golden CO / Merrick and Company





**SPRINGS ATG**  
**ADVANCED TECHNOLOGY GROUP**

**MBT Sister Company – Westminster, Colorado**

**[springsfabatg.com](http://springsfabatg.com)**



# INDUSTRIES & PRODUCTS

## **Industries Served:**

**Government (DOE & DOD)  
Commercial Nuclear  
Pharmaceutical  
Radio-Pharmaceutical  
Remediation**

## **Products:**

**Gloveboxes  
Hot Cells  
Isolators / Enclosures  
Restricted Access Barrier Systems  
(RABS/cRABS)  
Laminar Airflow (LAF) Equipment**



SPRINGS  
**FABRICATION**

**THANK YOU**

**SPRINGS FABRICATION, LLC**

Bob Djokovich, VP of Strategic Business Development  
850 Aeroplaza Drive, Colorado Springs, CO 80916

(719) 596.8830 – Main Office

(970) 481.9271 - Cell

[springsfab.com](http://springsfab.com)

---